

# Ironmaking Blast Furnace Above Burden Universal Probe

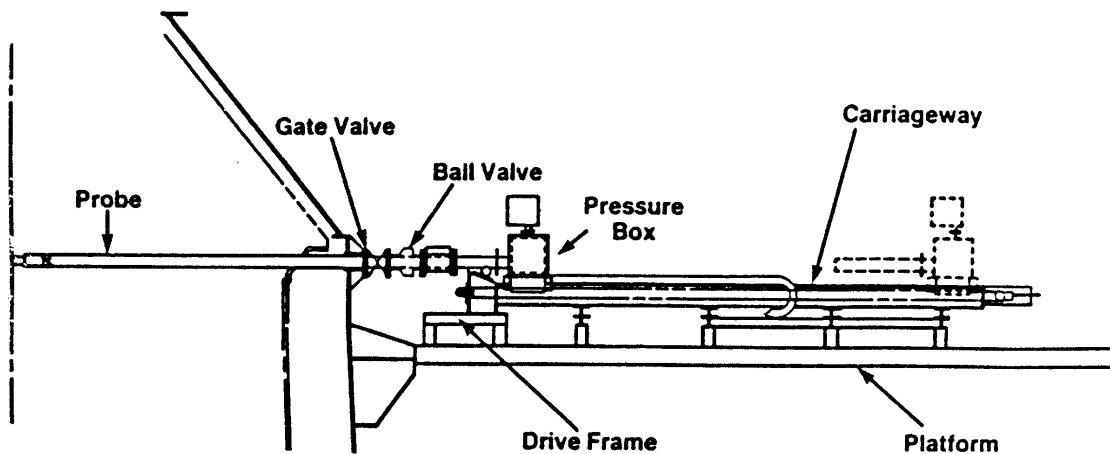

Corus Consulting Limited, Teesside Technology Centre, P.O. Box 11, Grangetown, Middlesbrough, Teesside TS6 6UB U.K. Telephone: +44 (0)1642 467144 Fax: +44 (0)1642 460321 E-mail: colin.notman@corusgroup.com

At present, there are three working units installed within Corus providing above-burden data on a routine basis.



Measurements taken above the stockline and across a radius in the furnace throat provide valuable information in assessing furnace operation. To supplement temperature only measuring probes, which Corus furnaces have used for many years, a multi-function probe has been developed. The universal probe measures not only top gas temperature, composition and velocity across the furnace, but also stockline burden profiles.

When not in operation, the probe sits behind two valves sealing against furnace pressure. On remote command, the valves open and the probe is driven into the furnace, whilst maintaining gas sealing with a nitrogen-purged stuffing box attached to the valve assembly. The probe stops to take measurements at, usually, six positions across the furnace radius before returning to an ambush position within the furnace wall. This procedure is then repeated a number of times, depending upon the operator's requirements, before returning to rest again behind the sealing valves. The whole process is controlled remotely and automatically by programmable logic control.

### Benefits:

- Essential investigative tool for blast furnace process control - provides valuable process information
- Helps maximise fuel efficiency (approximately 470Kg total fuel rate achieved regularly in Corus furnace)
- Significant contribution to extending furnace life (>15 years in British Steel) by improved operating stability
- Identifies blast furnace charging problems
- Provides information allowing improvements to be made to product quality and consistency (ie. HM Si SD<0.1)
- Ensures uniformity of burden distribution across the furnace
- Operates automatically and remotely whilst on blast

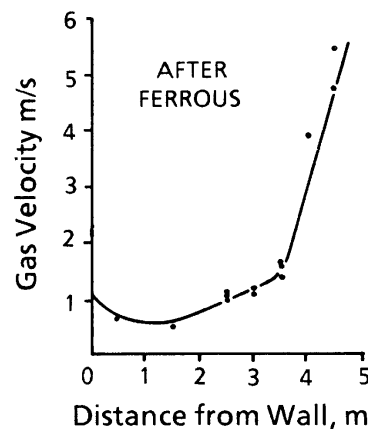
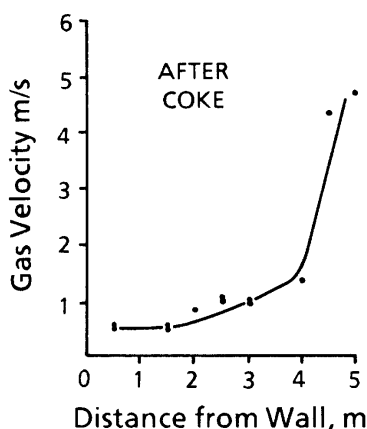

### VELOCITY MEASUREMENT